

INSTRUCTION MANUAL

MANUEL D'INSTRUCTIONS

MANUAL DE INSTRUCCIONES

Volume Control or Diverter Trim

(Style varies by model)

Garniture de soupape de contrôle du débit ou
d'inverseur

(Le style varie selon le modèle)

Moldura de control de volumen o desviador

(El estilo varía por el modelo)

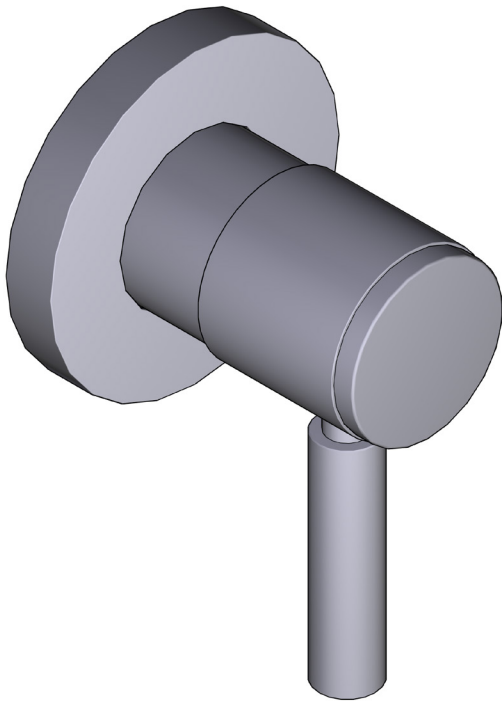

HELPFUL TOOLS

For safety and ease of installation, the use of these helpful tools is recommended.

OUTILS UTILES

Pour des raisons de sécurité et de facilité d'installation, l'utilisation de ces outils utiles est recommandée.

HERRAMIENTAS ÚTILES

Por seguridad y facilidad de instalación, se recomienda el uso de estas útiles herramientas.

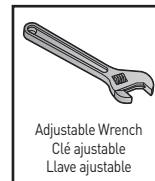

Adjustable Wrench
Clé ajustable
Llave ajustable



Hex Wrench
Clé hexagonale
Llave Hexagonal



Safety Glasses
Lunettes de sécurité
Gafas de seguridad

For warranty or additional information, contact:

US Customers

U.S.A.
houseofrohl.com/support
1-800-777-9762

Canadian Customers

QUEBEC / MARITIMES / WESTERN CANADA
QUÉBEC / MARITIMES / OUEST CANADIEN
QUEBEC / MARITIMOS / CANADA OCCIDENTAL
houseofrohl.ca/support
1-866-473-8442

ONTARIO
houseofrohl.ca/support
1-800-287-5354

Riobel®

Parts List

A. Wall Escutcheon & O-Ring *

B. Handle Assembly **

*O-Ring only available on certain models.

**Faucet component comes in various configurations.

Liste des pièces

A. Rosace murale et joint torique *

B. Assemblage de poignée **

*Le joint torique est offert dans le cas de certains modèles seulement.

**Les composants du robinet sont offerts en différentes versions.

Lista de piezas

A. Chapetón mural y junta tórica *

B. Ensamblado de la manija **

*La junta tórica solo está disponible en ciertos modelos.

**El componente de la llave está disponible en varias configuraciones.

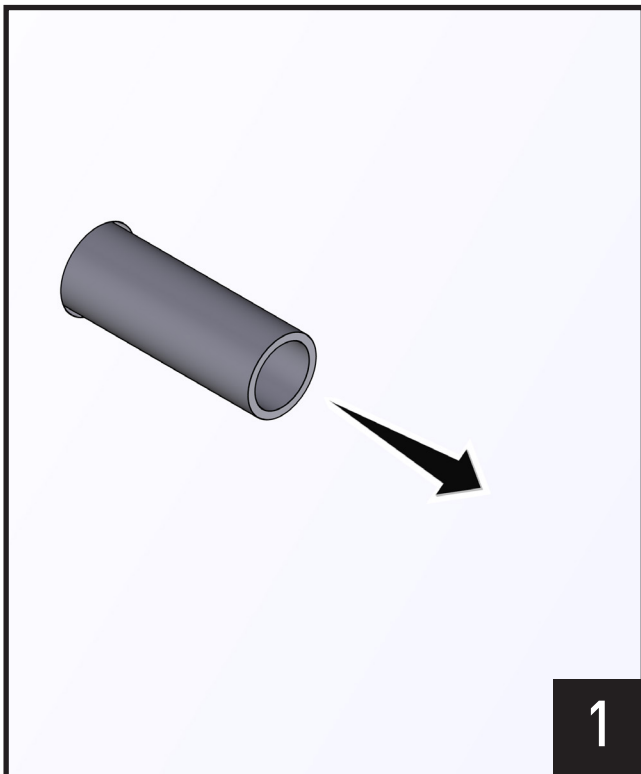
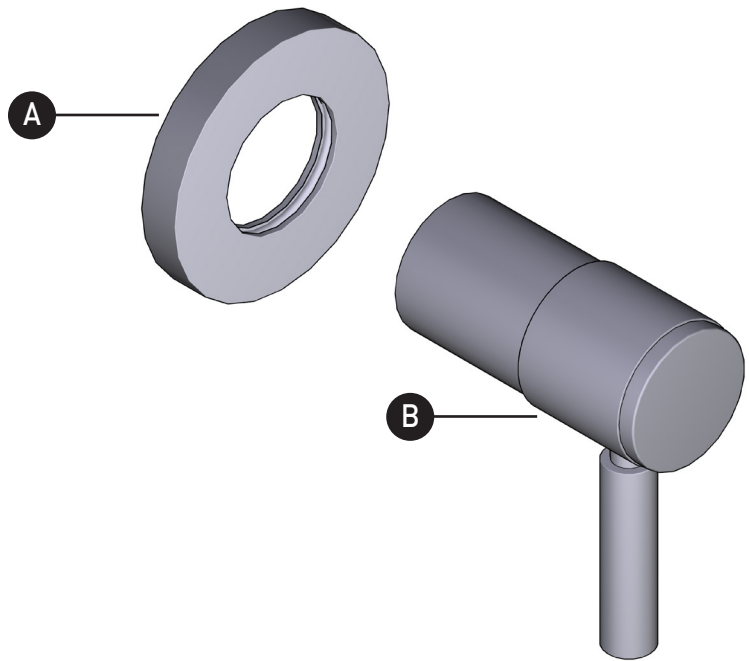

Remove and discard valve body dust cover to begin trim installation.

Enlever et jeter le couvercle antipoussière du corps de soupape pour commencer l'installation de la garniture.

Retire y deseche la cubierta antipolvo del cuerpo de la válvula para comenzar la instalación de la moldura.

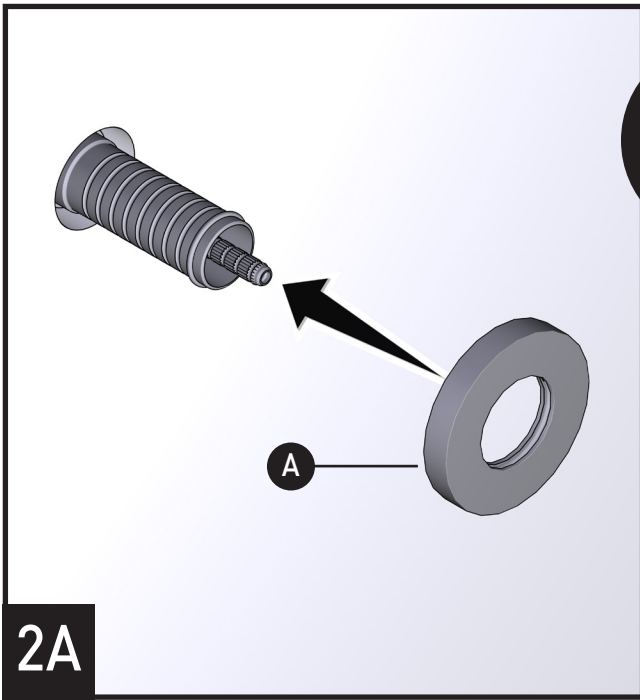

or
ou
o

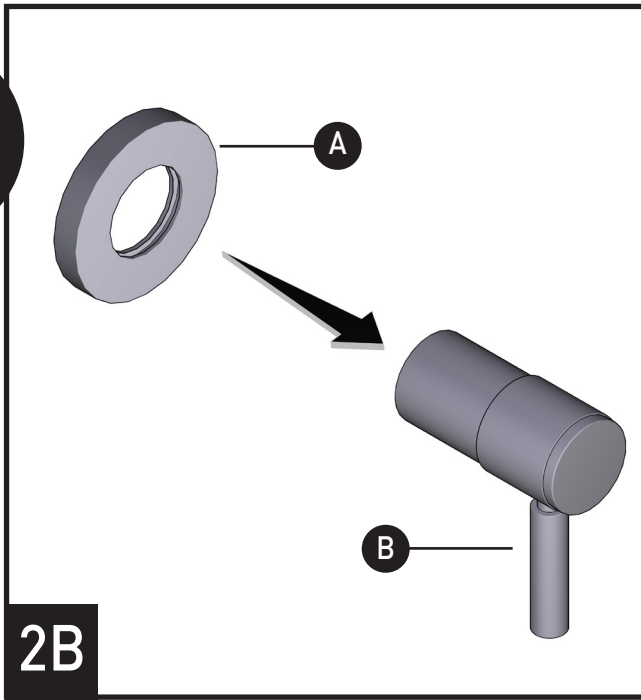

2A

2B

Install Wall Escutcheon & assembled O-Ring **(A)*** onto valve.
 Installer la rosace murale et le joint torique assemblé **(A)*** sur la soupape.
 Instale el chapetón mural y la junta tórica ensamblada **(A)*** en la válvula.

Install Wall Escutcheon **(A)*** onto Handle Assembly **(B)****.
 Installer la rosace murale **(A)*** sur l'assemblage de poignée **(B)****.
 Instale el chapetón mural **(A)*** en el ensamblado de la manija **(B)****.

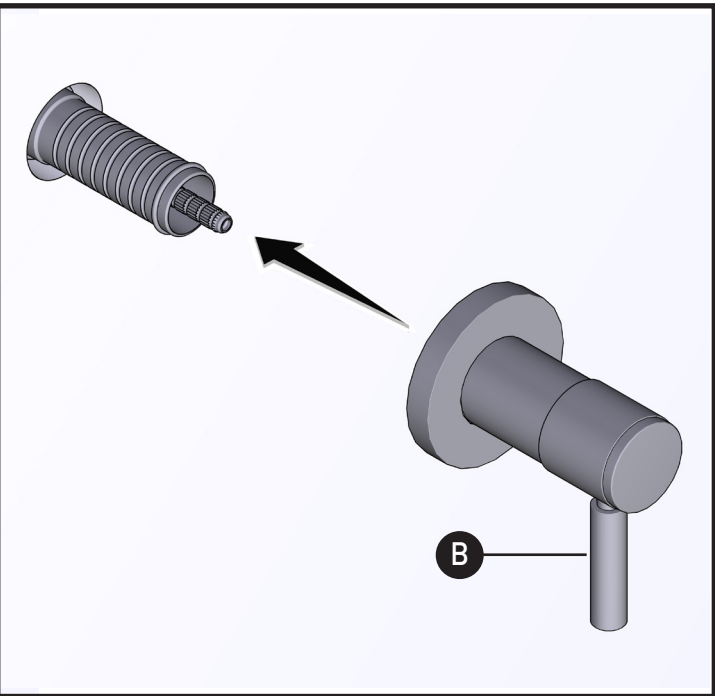
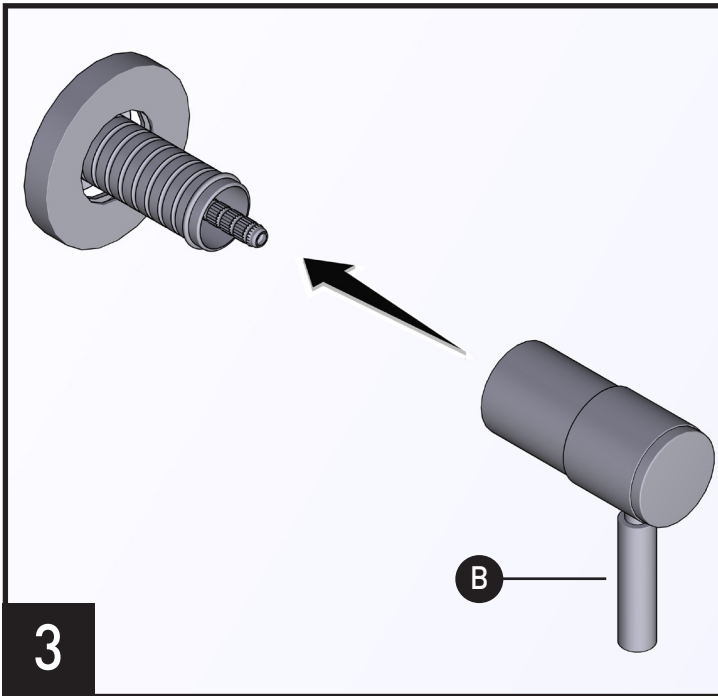

3

Install Handle Assembly **(B)**** onto valve.
 Installer l'assemblage de poignée **(B)**** sur la soupape.
 Instale el ensamblado de la manija **(B)**** en la válvula.

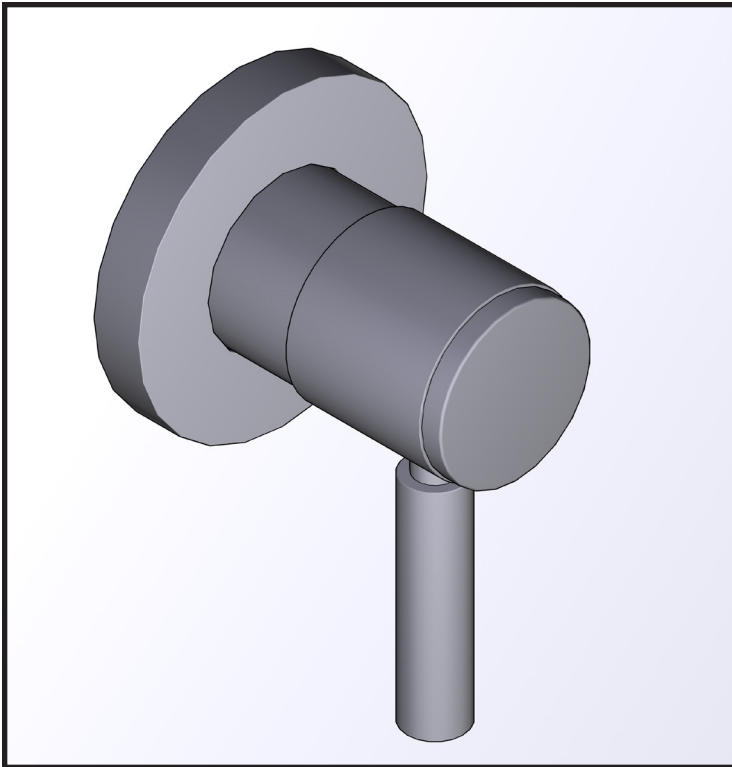

Installation is complete.
L'installation est terminée.
La instalación está completa.

For warranty or additional information, contact:

US Customers

U.S.A.
houseofrohl.com/support
1-800-777-9762

Canadian Customers

QUEBEC / MARITIMES / WESTERN CANADA
QUÉBEC / MARITIMES / OUEST CANADIEN
QUEBEC / MARITIMOS / CANADA OCCIDENTAL
houseofrohl.ca/support
1-866-473-8442

ONTARIO
houseofrohl.ca/support
1-800-287-5354

Riobel

PERRIN & ROWE
LONDON



victoria ⊕ albert®

ROHL